

Members:
Vickie Mullins, Chairman
George Lott, Vice-Chair
George Turner
Alfonso Ferguson Sr.
Winton McHenry



Alternates:
Robert E Davis
Nathan Galbreath
Stacy Michael Long
Alberta Ortiz
Gregory Parks

CUMBERLAND COUNTY BOARD OF ADJUSTMENT

130 Gillespie Street
Fayetteville North Carolina 28301
(910) 678-7602

AGENDA
AUGUST 17, 2017
7:00 PM

A meeting of the Cumberland County Board of Adjustment is to be held on Thursday, August 17, 2017, at 7:00 p.m. in Hearing Room #3 of the Historic Courthouse at 130 Gillespie Street, Fayetteville, North Carolina. The agenda is as follows:

1. INVOCATION & PLEDGE OF ALLEGIANCE
2. ROLL CALL
3. SWEAR IN STAFF
4. ADJUSTMENTS TO THE AGENDA
5. APPROVAL OF THE JUNE 15, 2017 MINUTES
6. ABSTENTIONS BY BOARD MEMBERS/BOARD MEMBER DISCLOSURES (SITE VISITS AND/OR PERSONAL AFFILIATIONS)
7. PUBLIC HEARING DEFERRALS/WITHDRAWALS
8. POLICY STATEMENT REGARDING APPEAL PROCESS
9. PUBLIC HEARING(S):
 - A. **P10-08-C:** MODIFICATION OF A SPECIAL USE PERMIT FOR A RECREATION VEHICLE PARK AND/OR CAMPGROUND IN AN A1 AGRICULTURAL DISTRICT ON 31.65 +/- ACRES TO ALLOW AN ADDITIONAL KITCHEN/STORAGE STRUCTURE, LOCATED AT 6250 WADE STEDMAN ROAD, SUBMITTED BY TAR HEEL RV RESORTS WADE LLC (OWNER) AND BRIAN T. GLOVER (AGENT).
 - B. **P17-04-C:** CONSIDERATION OF A SPECIAL USE PERMIT TO ALLOW GROUP QUARTERS IN AN A1 AGRICULTURAL DISTRICT ON 8.00 +/- ACRES, LOCATED AT 9386 E REEVES BRIDGE ROAD; SUBMITTED BY JOHN M. & DEBORAH FOLEY (OWNERS).
10. DISCUSSION/UPDATE(S)
11. ADJOURNMENT

Members:

Vickie Mullins, Chairman
George Lott, Vice-Chair
George Turner
Alfonso Ferguson Sr.
Winton McHenry

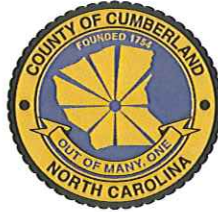

Alternates:

Robert E Davis
Nathan Galbreath
Stacy Michael Long
Alberta Ortiz
Gregory Parks

CUMBERLAND COUNTY BOARD OF ADJUSTMENT

130 Gillespie Street
Fayetteville North Carolina 28301
(910) 678-7602

MINUTES
June 15, 2017
7:00 PM

Members Present

Vickie Mullins
Alfonso Ferguson Sr.
George Lott
Stacy Michael Long, Alternate Voting
Robert E. Davis, Alternate Voting

Absent Members

Winton McHenry
George Turner

Staff/Others Present

Betty Lynd
Hope Ward Page
Robert Hasty, Jr. (Assistant
County Attorney)

Chairman Mullins called the meeting to order at 7:00 p.m. in Public Hearing Room #3 of the Historic Courthouse. Chairman Mullins stated the procedural matters are to turn off all cell phones and other electronic devices and if asked to speak at the podium to please speak clearly into the microphone as the meeting is being recorded. If any board member wishes to speak or ask any questions please ask to be recognized by the Chairman before speaking.

1. INVOCATION

Mr. Lott.

PLEDGE OF ALLEGIANCE

Recited by all.

2. ROLL CALL

Mrs. Lynd called the roll and stated a quorum was present. For the audience Mrs. Lynd introduced, Mr. Robert Hasty, Assistant County Attorney.

3. SWEAR IN STAFF

Mr. Lott swore in staff.

4. ELECTION OF OFFICERS

MRS. LYND: Yes, Madam Chair. Item four is election of officers. Every fiscal year the Board has a Chair and Vice-Chair voted in. It can be the same Chair and Vice-Chair; or it can be new members, whatever the Board desires. But you do need to nominate someone and make a motion and vote them in.

CHAIR MULLINS: Okay. We only have two...

MR. LOTT: Can I make a motion?

MRS. LYND: Yes you can make a motion.

MR. LOTT: I'd like to nominate Vickie Mullins as our Chair.

MR. FERGUSON: Second.

CHAIR MULLINS: All in favor say aye.

Mr. Lott made a motion to nominate Vickie Mullins as Cumberland County Board of Adjustment Chair, seconded by Mr. Ferguson. The motion passed unanimously.

IN FAVOR	
MULLINS	YES
LOTT	YES
FERGUSON	YES
LONG	YES
DAVIS	YES

CHAIR MULLINS: I'd like to nominate, can I do that?

MR. LOTT: Yes.

CHAIR MULLINS: Okay, I didn't know if I could do that or not. So I'd like to nominate George Lott for Vice-Chair.

MR. FERGUSON: Second.

CHAIR MULLINS: All in favor say aye.

Chair Mullins made a motion to nominate George Lott as Cumberland County Board of Adjustment Vice-Chair, seconded by Mr. Ferguson. The motion passed unanimously.

IN FAVOR	
MULLINS	YES
LOTT	YES
FERGUSON	YES
LONG	YES
DAVIS	YES

5. ADJUSTMENTS TO THE AGENDA

There were none.

6. APPROVAL OF THE APRIL 20, 2017 MINUTES

Mr. Lott made a motion to approve the minutes as submitted, seconded by Mr. Davis. The motion passed unanimously.

IN FAVOR	
MULLINS	YES
LOTT	YES
FERGUSON	YES
LONG	YES
DAVIS	YES

7. ABSTENTIONS BY BOARD MEMBERS/BOARD MEMBER DISCLOSURES (SITE VISITS AND/OR PERSONAL AFFILIATIONS)

There were none.

8. PUBLIC HEARING DEFERRALS/WITHDRAWALS

There were none.

8. POLICY STATEMENT REGARDING APPEAL PROCESS

Mrs. Lynd read the policy statement.

9. PUBLIC HEARING(S)

- A. **P02-19-C: REVOCATION OF A SPECIAL USE PERMIT FOR A BEAUTY SHOP IN AN A1 AGRICULTURAL DISTRICT ON 0.32 +/- ACRE, LOCATED AT 2434 COUNTY LINE ROAD, SUBMITTED BY CHRISTOPHER BROCK (OWNER).**

Chair Mullins read the case heading for Case No. P02-19-C.

Mrs. Lynd reviewed the zoning, sketch map, and land use of the area surrounding subject property. She briefly reviewed board packet material.

MRS. LYND: Basically in July of 2002, the applicant or the owners of the property applied for a special use permit which was required at that time for them to operate a beauty salon on this property. The beauty salon has since ceased business and they are wanting to renovate it back into a residential home. In order to do that the special use permit for the beauty salon must be revoked. And that's basically the request, the applicants are here you can call them up to speak if you desire if not the board may discuss and make a motion.

CHAIR MULLINS: Okay. Thank you Mrs. Lynd, anybody have any questions?

MR. LOTT: No.

CHAIR MULLINS: Would you like for them to speak?

MR. LOTT: Ask them if they want to.

CHAIR MULLINS: Would you like to speak?

MR. BROCK: No ma'am not if I don't have to.

CHAIR MULLINS: That's fine. Okay, somebody want to make a motion?

MR. LOTT: I make a motion that we approve the revocation.

MR. DAVIS: Second.

CHAIR MULLINS: All in favor?

Mr. Lott made a motion to approve the applicants request to revoke the special use permit, seconded by Mr. Davis. The motion passed unanimously.

	IN FAVOR
MULLINS	YES
LOTT	YES
FERGUSON	YES
LONG	YES
DAVIS	YES

CHAIR MULLINS: Okay. Any other discussion?

MR. BROCK: That's it?

MR. LOTT: That's it you can go.

CHAIR MULLINS: Yes.

MRS. LYND: You may leave.

11. DISCUSSION/UPDATE(S)

MRS. LYND: The only update from staff would be, we have no cases in for the deadline for July meeting so there will be no meeting in July.

CHAIR MULLINS: Okay.

MRS. LYND: I don't know. I don't think Mr. Hasty has heard anything back concerning...

MR. HASTY: No, we're still waiting on that Court of Appeals case. It's been a long time. I don't know what to read into that.

MR. LOTT: That's on which one?

MR. HASTY: That's that citation given to the shoot range. We argued that in January, they usually return a decision within thirty-sixty days but this is taking a while.

CHAIR MULLINS: Well if there is nothing else then.

12. ADJOURNMENT

MR. DAVIS: I make a motion that this meeting be adjourned.

MR. FERGUSON: Second.

CHAIR MULLINS: All in favor?

Mr. Davis made motion to adjourn, seconded by Mr. Ferguson. The motion passed unanimously. Meeting adjourned at 7:10pm.

	IN FAVOR
MULLINS	YES
LOTT	YES
FERGUSON	YES
LONG	YES
DAVIS	YES

SITE PROFILE: P10-08-C

P10-08-C: MODIFICATION OF A SPECIAL USE PERMIT FOR A RECREATION VEHICLE PARK AND/OR CAMPGROUND IN AN A1 AGRICULTURAL DISTRICT ON 31.65 +/- ACRES TO ALLOW AN ADDITIONAL KITCHEN/STORAGE STRUCTURE, LOCATED AT 6250 WADE STEDMAN ROAD, SUBMITTED BY TAR HEEL RV RESORTS WADE LLC (OWNER) AND BRIAN T. GLOVER (AGENT).

Cumberland County Zoning Ordinance Reference: Section 921. Recreation Vehicle Park and/or Campground

Notes:

Application:

1. Additional 50' by 65' kitchen/storage structure on an approved/existing recreation vehicle park.

The property owner has agreed to all ordinance-related conditions.

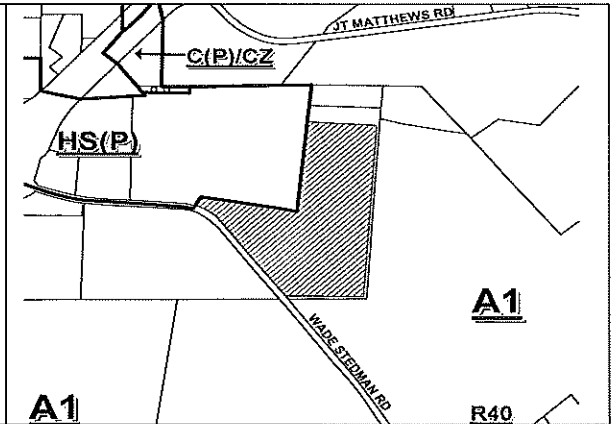

<p>INITIAL ZONING HS(P)- November 25, 1980 (Area 14)</p> <p>JURISDICTION Cumberland County</p> <p>MUNICIPAL INFLUENCE AREA Wade</p>	<p>ADJACENT PROPERTY None</p> <p>CURRENT USE Recreational Vehicle Park and/or Campground</p>	<p>NONCONFORMITIES No</p> <p>ZONING VIOLATIONS None issued</p>	<p>WATER/SEWER AVAILABILITY Well/Septic</p> <p>SOIL LIMITATIONS Yes: Hydric Inclusion (St-Stallings loamy sand)</p> <p>WATERSHED No</p> <p>SPECIAL FLOOD HAZARD AREA No</p>	<p>SIZE OF PROPERTY</p> <p>Frontage & Location: 1167.00' on SR 1815 (Wade-Stedman Rd)</p> <p>Depth: 1466.00'</p>
--	--	--	---	---

<p>SURROUNDING ZONING</p> <p>North: A1, C(P)/CZ (motor vehicle repair), M2 West: A1, HS(P), C(P), M(P) East: A1 South: A1, R40, RR</p>	<p>SURROUNDING LAND USE</p> <p>Residential, Vacant convenience store, Farmland and woodlands</p>
<p>COMPREHENSIVE PLANNING:</p> <p>2030 Growth Strategy Plan: Community Growth Area Wade Land Use Plan: Planned Commercial</p>	<p>TRANSPORTATION PLANNING:</p> <p>Wade-Stedman Road is identified as an existing thoroughfare in the 2040 Metropolitan Transportation Plan with no constructions/improvements planned. The subject property will have no impact on the Transportation Improvement Plan.</p>

OTHER PROPERTY INFO:

School Capacity/Enrolled: District 7 Elementary: 300/265; Mac Williams Middle: 1270/1165; Cape Fear High: 1425/1534

Subdivision/Site Plan: See attached "Ordinance Related Conditions"

Average Daily Traffic Count (2014): 1,300 on SR 1815 (Wade-Stedman Rd)

US Fish & Wildlife: No objection

All documentation required by the ordinance is attached to the application or contained within the case file, and is available for review upon request.

First Class and Record Owners' Mailed Notice Certification

A certified copy of the listing with the tax record owner(s) of the subject and adjacent properties, along with their tax record mailing addresses, is contained within the case file and incorporated by reference as if delivered herewith.

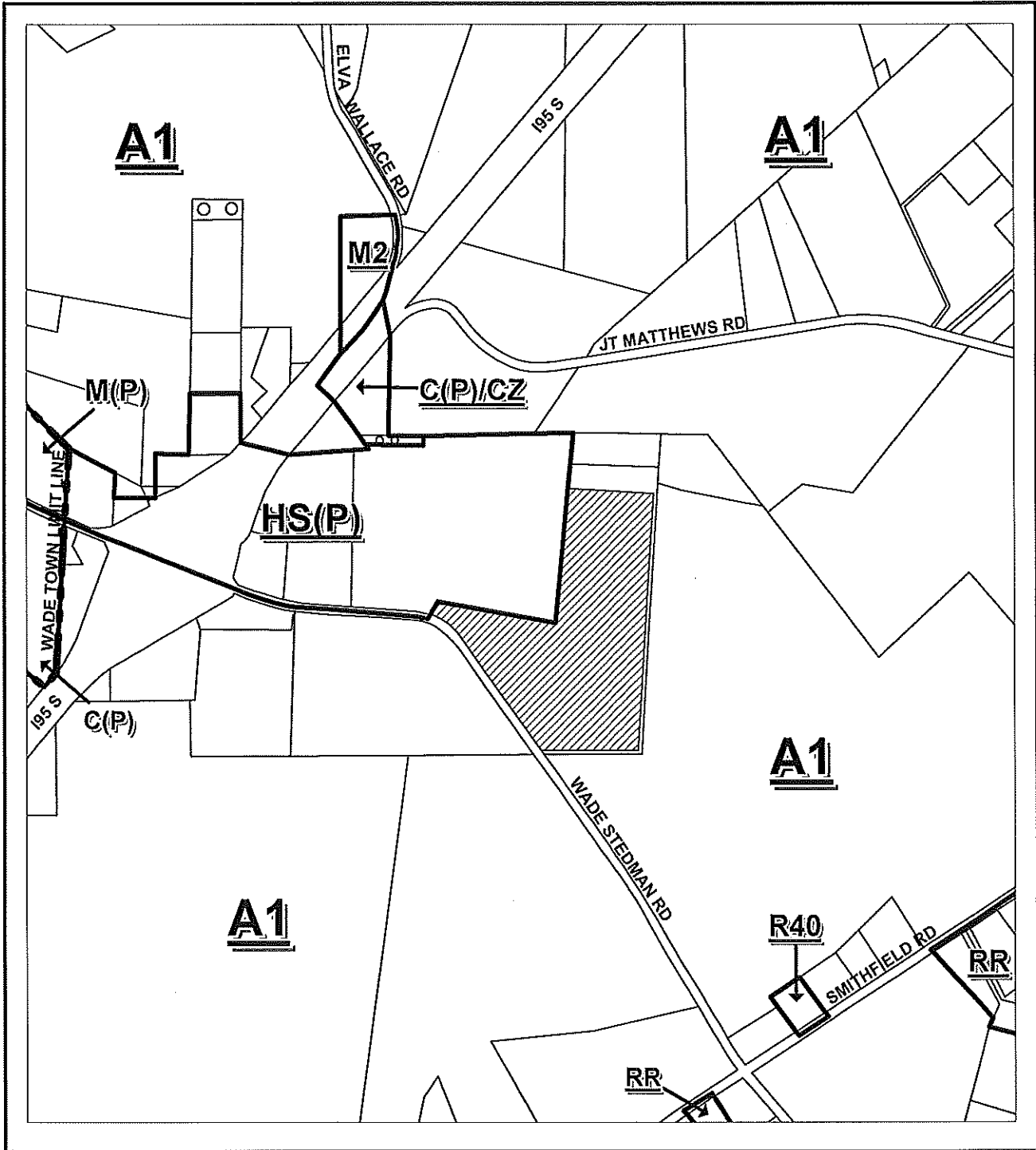

**BOARD OF ADJUSTMENT
MODIFICATION OF
SPECIAL USE PERMIT**

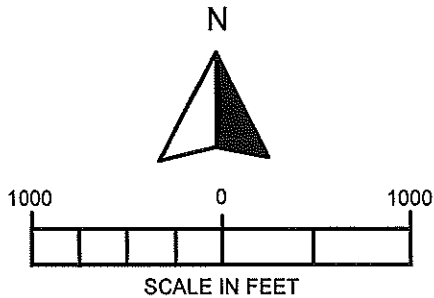

ACREAGE: 31.65 AC.+/-		HEARING NO: P10-08-C	
ORDINANCE: COUNTY		HEARING DATE	ACTION
GOVERNING BOARD			

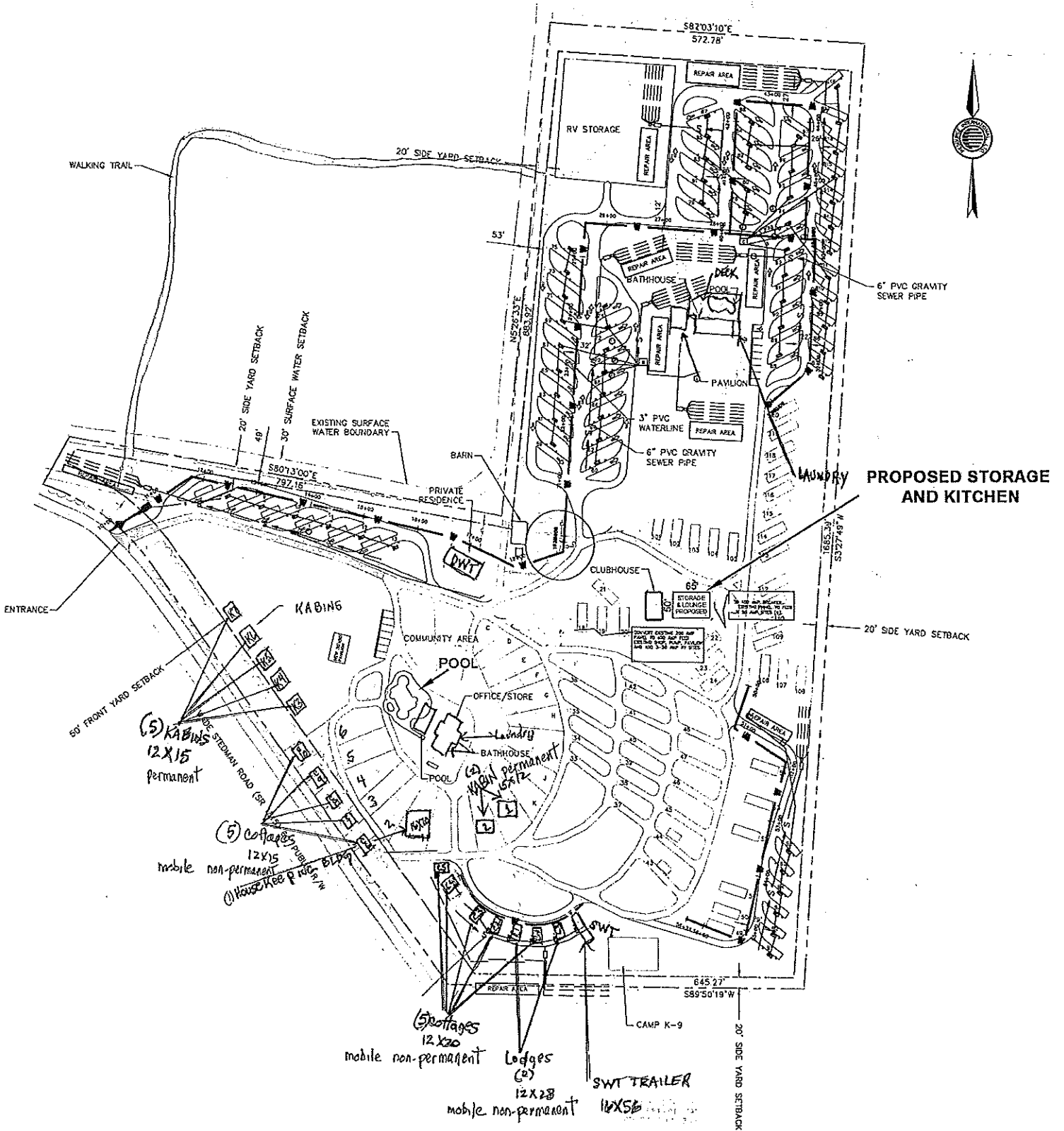

BOARD OF ADJUSTMENT
MODIFICATION OF SPECIAL USE PERMIT
REQUEST: TO ALLOW AN ADDITIONAL KITCHEN/STORAGE STRUCTURE
CASE: P10-08-C ACREAGE: 31.65 AC +/-
ZONED: A1 SCALE: NTS

* SCALED DETAILED SITE PLAN IN FILE AVAILABLE FOR REVIEW UPON REQUEST

Special Use Permit – Board of Adjustment

DRAFT

Ordinance Related Conditions

Recreational Vehicle Park and/or Campground (Additional kitchen/storage structure)

Per-Permit-Related:

1. Three copies of a revised site plan must be submitted for staff review and approval and include the following:
 - a. The relocation of the “trailer” (manufactured home) to be used as a watchman quarters meeting the minimum setback requirement of 100 feet from SR 1815 (Wade Stedman Road).
 - b. This conditional approval is not approval of any freestanding signs. If a freestanding sign is desired, the sign location must be shown on the site plan. Attached signage for this development must be in accordance with the applicable sign regulations as set forth in Article XIII of the County Zoning Ordinance and that the proper permit(s) must be obtained prior to the installation of any permanent signs on the property. (Note: This conditional approval is not approval of the size, shape, or location of any signs.)
 - c. Landscaping must be provided in accordance with Section 1102 N, Landscaping, County Zoning Ordinance and/as shown on the site plan. The following are the minimum standards for the required landscaping of this site:
 1. Ten large shade trees or 20 small ornamental trees within the front yard setback area;
 2. One large shade trees and ten shrubs are required in the building yard area;

In addition:

1. Required plant materials shall be maintained by the property owner, including replacing dead or unhealthy trees and shrubs; and
2. All yard and planting areas shall be maintained in a neat, orderly, and presentable manner and kept free of weeds and debris.

Permit-Related:

2. The owner/developer(s) of these lots must obtain detailed instructions on provisions of the County Zoning Ordinance and permits required to place any structure within this development from the County Code Enforcement Section, Room 101 in the Historic Courthouse at 130 Gillespie Street. For additional information, the developer should contact a Code Enforcement Officer.
3. The County Health Department must approve water and sewer plans prior to application for any permits. Site and soil evaluations must be conducted on the property by the County Environmental Health Department prior to application for permits. A copy of the Health Department approval must be provided to Code Enforcement at the time of application for any building/zoning permits. (Note: All Health Department requirements must be met prior to issuance of final permits.) (Section 2306 A, Water and Sewer, County Subdivision Ordinance) **Note: The County Health Department must approve plans for the kitchen portion of the proposed structure prior to application for permits.**
4. New development that will disturb one acre or more of land or is part of a larger plan that will disturb at least an acre of land is subject to the Post-Construction Stormwater Management Permitting Program (Phase II Stormwater Management Requirements) administered by the Division of Water Quality, North Carolina Department of Environment and Natural Resources. If one acre or more of land is to be disturbed, prior to the issuance of any building/zoning permits for this site, a copy of the State’s *Post-Construction Permit* must be provided to County Code Enforcement.
5. For any new development, the developer must/may have to provide the Code Enforcement Section with an approved NC Department of Environment and Natural Resources (NCDENR) sedimentation and erosion control plan (S&E) prior to any application for permits. (Note: If any retention/detention basins are required for state approval of this plan, then three copies of a revised plan must be submitted and approved by Planning & Inspections prior to application for any building/zoning permits.) A copy of the NCDENR approval must be provided to Code Enforcement at the time of application for any building/zoning permits.

Note: The plan review time is 30 days (by statute) and the fee is \$65.00 per acre. The plan is to be submitted to the local regional office for review.

6. The developer must provide a site-specific address and tax parcel number at the time of building/zoning permit application.
7. The building final inspection cannot be accomplished until a Code Enforcement Officer inspects the site and certifies that the site is developed in accordance with the approved plans.

Site-Related:

8. All uses, dimensions, setbacks and other related provisions of the County Subdivision and Zoning Ordinances for the A1 zoning district must be complied with, as applicable.
9. A minimum four foot high fence completely enclosing all pools on this site is mandatory.
10. For any new development, an adequate drainage system must be installed by the developer in accordance with the NC Department of Environment and Natural Resources’ (NCDENR) *Manual on Best Management Practices* and all drainage ways must be kept clean and free of debris

11. If Eastover Sanitary District water is available at the time application for permits are submitted, a fire hydrant must be installed along SR 1815 (Wade-Stedman Road); hydrants must be located no further than 1,000 feet apart and at a maximum of 500 feet from any lot/unit.
12. For new development, all utilities, except for 25kv or greater electrical lines, must be located underground. (Section 2306 C, County Subdivision Ordinance)
13. The developer must obtain a driveway permit from the NC Department of Transportation (NCDOT). A copy of the approved driveway permit must be provided to Code Enforcement at the time of application for building/zoning permits.
14. Turn lanes may be required by the NC Department of Transportation (NCDOT).
15. The entire development must be served by the existing internal drive system.
16. All lighting is required to be directed internally within this development and comply with the provisions of Section 1102 M, Outdoor Lighting, County Zoning Ordinance.
17. All dumpster, garbage, and utility areas shall be located on concrete pads and screened on a minimum of three sides.
18. The owner/developer is responsible and liable for maintenance and upkeep of this site, all structures, and appurtenances, to include ensuring that the site is kept free of litter and debris, all grass areas mowed, all buffers and shrubbery kept trim and maintained, so that the site remains in a constant state of being aesthetically and environmentally pleasing.
19. All notes and calculations as shown on the site plan and contained within the application are to be considered as a part of this conditional approval.

Advisories:

20. The applicant is advised to consult an expert on wetlands before proceeding with any development.
21. The owner/developer is responsible for ensuring easements which may exist on the subject property are accounted for, not encumbered and that no part of this development is violating the rights of the easement holder.

Other Relevant Conditions:

22. The recreational vehicle park/campground shall not allow for permanent occupancy of any RV or campsite within this development; the same RV cannot remain on the same site for a continuous period of time exceeding 90 days.

If you need clarification of any conditions, please contact Ed Byrne at 910-678-7609 or Patti Speicher at 910-678-7605; otherwise, contact the appropriate agency at the contact numbers below.

Contact Information (Area Code is 910 unless otherwise stated):

Subdivision/Site Plan/Plat	Ed Byrne	678-7609
Code Enforcement (Permits):	Ken Sykes	321-6654
County Engineer's Office:	Wayne Dudley	678-7636
County Health Department:	Daniel Ortiz	433-3680
Ground Water Issues:	Matt Rooney	678-7625
Eastover Sanitary District:	Morgan Johnson	323-3973
Town of Wade (Wade MIA):	Jennifer Oppenlander (Staff Rep)	678-7629
Town of Wade:	Cindy Burchett (Town Clerk)	485-3502
County Public Utilities/NORCRESS:	Tom Cooney	678-7682
Corp of Engineers (wetlands):	Crystal C. Amschler	251-4170
NC DENR (E&S):	Sally McKinney	433-3300
E911 Site-Specific Address:	Ron Gonzales	678-7616
Tax Parcel Numbers:		678-7549
NCDOT (driveways/curb-cuts):	Gary Burton	486-1496
N.C. Division of Water Quality:	Mike Randall	(919) 733-5083 ext. 545

BOARD OF ADJUSTMENT

LOCATION OF PROPERTY: 6250 WADE-Stedman Rd.

OWNER: TARHEEL RV Resorts WADE LLC
RV Management Services, LLC Phillip Moreau

ADDRESS: 6250 WADE-Stedman Rd. WADE NC ZIP CODE: 28395

TELEPHONE: HOME _____ WORK 301-252-5600

AGENT: Brian T. Toliver

ADDRESS: 7658 New Sandy Hill Ch. Rd. # Sims, NC 27580

TELEPHONE: HOME 252-205-3081 WORK _____

E-MAIL: briant@basogun.com

APPLICATION FOR A SPECIAL USE PERMIT
As required by the Zoning Ordinance

A. Parcel Identification Number (PIN #) of subject property: 0581-72-6510
(also known as Tax ID Number or Property Tax ID)

B. Acreage: 31.65 Frontage: 1167' Depth: 1466'

C. Water Provider: Well

D. Septage Provider: septic system

E. Deed Book 7925, Page(s) 42, Cumberland County Registry. (Attach copy of deed of subject property as it appears in Registry).

F. Existing use of property: RV Campground

G. It is proposed that the property will be put to the following use: (Describe proposed use/activity in detail including hours of operation, number of employees, signage, parking, landscaping, etc.)

" See Attachment A "

(Attachment A)

Fayetteville RV Resort & Cottages (the "Property") has become a well recognized, high quality RV Resort since a major renovation that started in 2010 when the current owner assumed control. In fact, the authoritative, 800 page "Good Sam RV Travel Guide & Directory" has rated the Property "10 / 10+ / 10" and is one of approximately 135 such "perfect" RV Resorts out of the 6500 RV resorts rated by Good Sam.

The Property has a modest marquee sign at the entrance to the Property on Wade Stedman Road. Currently the property has only 164 RV sites, all of which are FHU (full hook up with water, sewer and electric). Each site is well landscaped with a burm consisting of a mix of small trees, shrubs and flowers. With ample parking at the large sites, many of which also have huge trees adjacent to the site in addition to the burms, additional parking is scattered throughout the Property, provided another 50 or so spaces. The Property has approximately 6 to 11 employees, depending on the season and generally operates seven days a week from 9am to 5pm with slightly longer hours in the summer months.

Amenities at the Property include an office check-in building that includes a small retail display area, a small laundrette and small bathhouse facilities; a new swimming pool that currently is being built at the front of this check-in building; a second smaller pool towards the back of the Property that is five years old; a fitness room; another bathhouse with six private bathroom suites and a small laundrette; and a small clubhouse; a state of the art miniature golf course; a children's playground; a basketball court painted "Tar Heel blue"; and two small dog parks.

The ambiance of the Property is evident from when an RVer first drive into the Property on the paved driveway to when the RVer encounters the care and respect provided by our value driven staff.

* The new lounge building we are hoping to now construct will provide much needed storage space for activity equipment and for additional mechanical equipment that needs a controlled environment, such as WiFi and Cable TV equipment. The new building will also have a computer lounge area with a "hotspot", a TV for public use, and a small warming kitchen for the occasional "pot-luck" dinner that our guests prepare in their RVs.

The undersigned hereby acknowledge that the County Planning Staff has conferred with the petitioner or assigns, and the application as submitted is accurate and correct.

TARHEEL RV Resorts LLC, Phillip Morcan.
NAME OF OWNER(S) (PRINT OR TYPE)

25515 Via Marquita Carmel CA 93923
ADDRESS OF OWNER(S)

divinrvpsm@aol.com
E-MAIL

HOME TELEPHONE # _____ WORK TELEPHONE # 301-252-5600

Brian T Glover
NAME OF AGENT, ATTORNEY, APPLICANT (PRINT OR TYPE)

7658 New Sandy Hill Church Rd. Sims NC 27880
ADDRESS OF AGENT, ATTORNEY, APPLICANT

briang@basco.gu.com
E-MAIL

252-205-3081
HOME TELEPHONE #

WORK TELEPHONE # _____

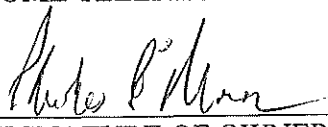
SIGNATURE OF OWNER(S)

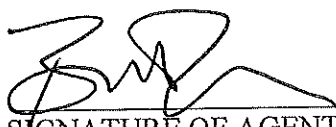
SIGNATURE OF AGENT, ATTORNEY OR APPLICANT

SIGNATURE OF OWNER(S)

The contents of this application, upon submission, become "public record."

STATEMENT OF ACKNOWLEDGMENT

Regarding appearance before the Board of Adjustment, the undersigned owner(s), agents, or their assigns, by virtue of their signature(s) to this application, hereby acknowledge the following:

- That although appearance before the board is not required, it is strongly encouraged;
- The board will hear any and all argument for and against this matter before them and such relevant facts will be given under sworn testimony;
- At the public hearing the board has the authority to approve, deny, or defer the request for additional information to be provided;
- If the petitioner or their representative for this application does not appear personally before the board, whether there is opposition or not, the board has full authority to consider the case.
- If the board's decision is to deny the matter before them, the aggrieved party shall file a **"Notice to Intent to Appeal" with the Planning & Inspections Staff on the next business day following the meeting in which the board's decision was made final, or the next business day following receipt of the written copy thereof.**
- Any petition for review by Superior Court shall be file with the Clerk of Superior Court within 30 days after the decision of the board is made final.

Signed acknowledgment that the Planning and Inspections Staff has explained the application process and procedures regarding this request and the public hearing procedure stated above.

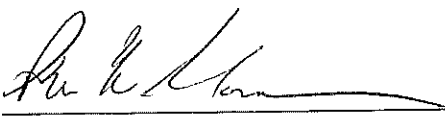
SIGNATURE OF OWNER(S) 

PRINTED NAME OF OWNER(S) Phillip Moreau

DATE 6-7-17

P17-04-C: CONSIDERATION OF A SPECIAL USE PERMIT TO ALLOW GROUP QUARTERS IN AN A1 AGRICULTURAL DISTRICT ON 8.00 +/- ACRES, LOCATED AT 9386 E REEVES BRIDGE ROAD; SUBMITTED BY JOHN M. & DEBORAH FOLEY (OWNERS).

Cumberland County Zoning Ordinance Reference: Section 910. Group Quarters

Notes:

Application:

1. Proposed group quarters facility with four resident houses, one staff house, and one common building.
2. The facility will operate 40 retreats a year.

The property owner has agreed to all ordinance-related conditions.

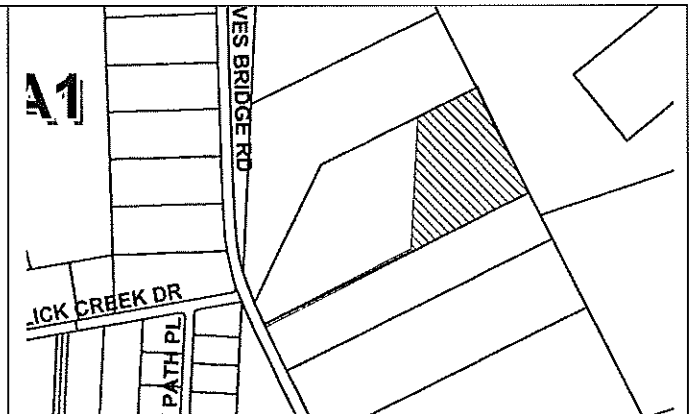

INITIAL ZONING A1- December 17, 2001 (Area 15)	ADJACENT PROPERTY Yes	NONCONFORMITIES None	WATER/SEWER AVAILABILITY Linden/Septic	SIZE OF PROPERTY Frontage & Location: 20.00' on SR 1609 (East Reeves Bridge Rd)
JURISDICTION Cumberland County	CURRENT USE Vacant	ZONING VIOLATIONS None issued	SOIL LIMITATIONS Yes- Ro (Roanoke and Wahee loams)	Depth: 1574.12'
MUNICIPAL INFLUENCE AREA N/A			WATERSHED No	
			SPECIAL FLOOD HAZARD AREA No	

SURROUNDING ZONING North: A1, R40, R40A, R30, R20 West: A1 East: A1 South: A1, RR	SURROUNDING LAND USE Residential, Horses that Heal, Farmlands and woodlands
COMPREHENSIVE PLANNING: 2030 Growth Strategy Plan: Rural Areas North Central Cumberland Land Use Plan: Farmland	TRANSPORTATION PLANNING: East Reeves Bridge Road is identified as an existing thoroughfare in the 2040 Metropolitan Transportation Plan with no constructions/improvements planned. The subject property will have no impact on the Transportation Improvement Plan.

OTHER PROPERTY INFO:

School Capacity/Enrolled: Raleigh Road Elementary: 220/234; Long Hill Elementary: 460/448; Pine Forest Middle: 820/762; Pine Forest High: 1750/1557

Subdivision/Site Plan: See attached "Ordinance Related Conditions"

Average Daily Traffic Count (2014): 430 on SR 1609 (East Reeves Bridge Rd)

US Fish & Wildlife: No objection

All documentation required by the ordinance is attached to the application or contained within the case file, and is available for review upon request.

First Class and Record Owners' Mailed Notice Certification

A certified copy of the listing with the tax record owner(s) of the subject and adjacent properties, along with their tax record mailing addresses, is contained within the case file and incorporated by reference as if delivered herewith.

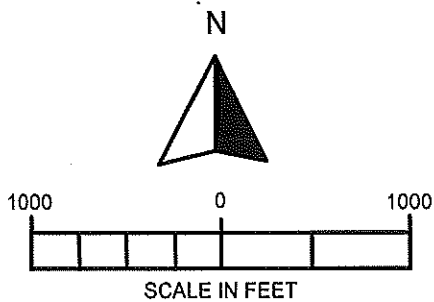
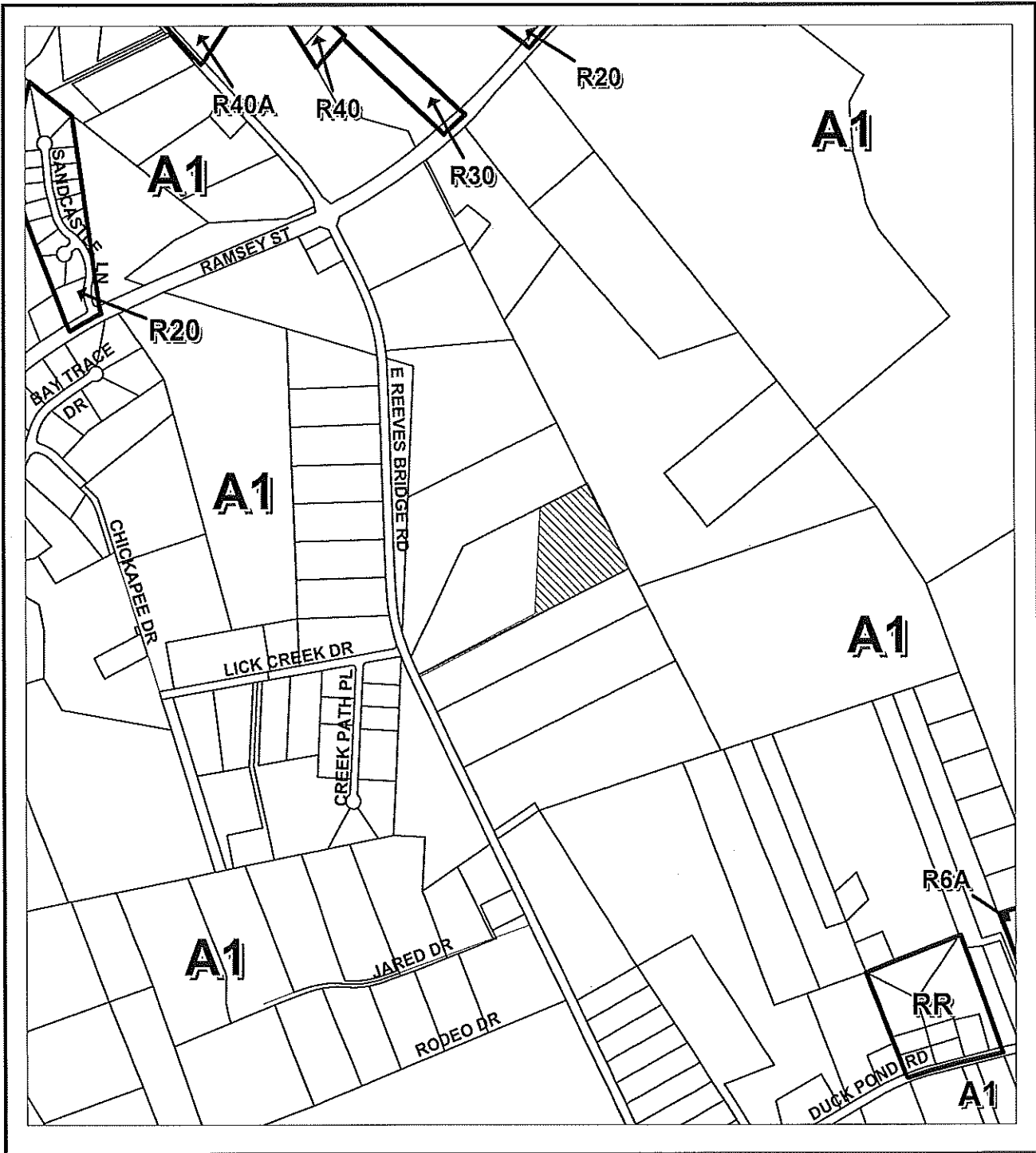

BOARD OF ADJUSTMENT SPECIAL USE PERMIT

ACREAGE: 8.00 AC.+/-	HEARING NO: P17-04-C	
ORDINANCE: COUNTY	HEARING DATE	ACTION
GOVERNING BOARD		

PORT OF PIN: 0554-51-6231

MB

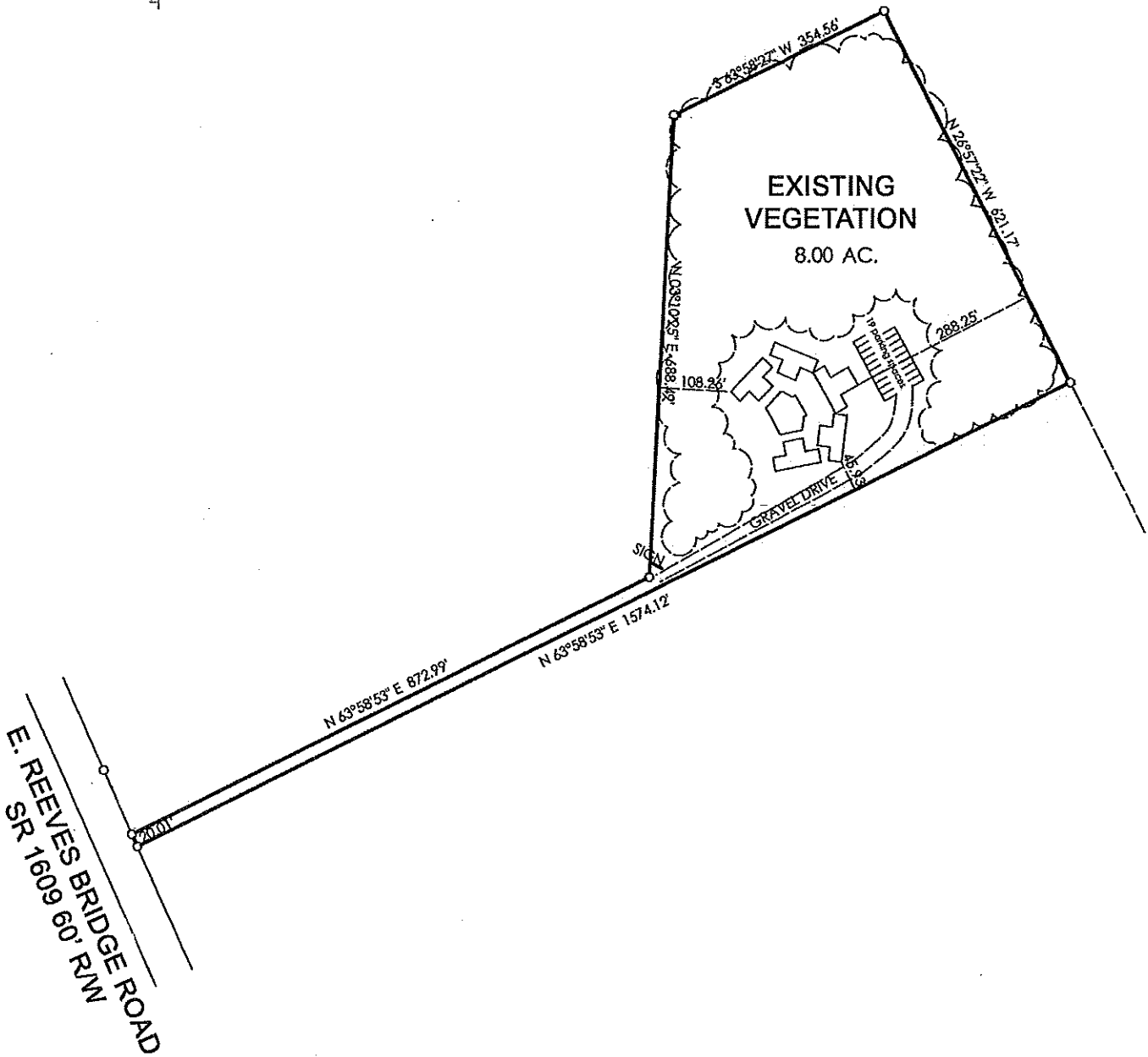
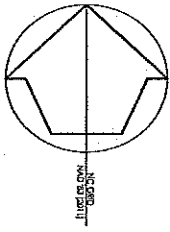

BOARD OF ADJUSTMENT SPECIAL USE PERMIT

REQUEST: TO ALLOW GROUP QUARTERS IN AN
A1 AGRICULTURAL DISTRICT
CASE: P17-04-C ACREAGE: 8.00 AC +/-
ZONED: A1 SCATE: NTS

*SCALED DETAILED SITE PLAN IN FILE AVAILABLE FOR REVIEW UPON REQUEST

P17-04-C

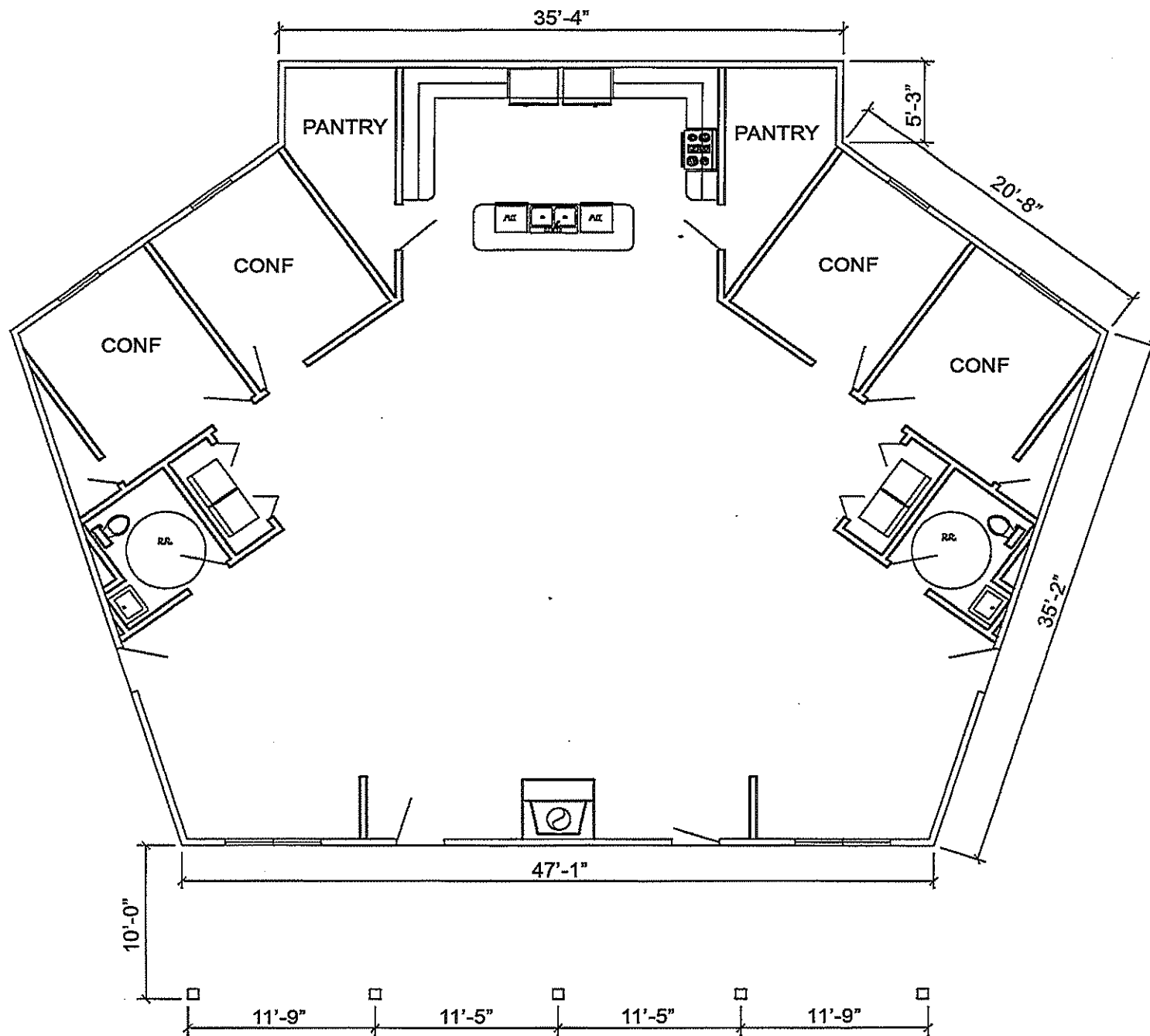

P17-04-C

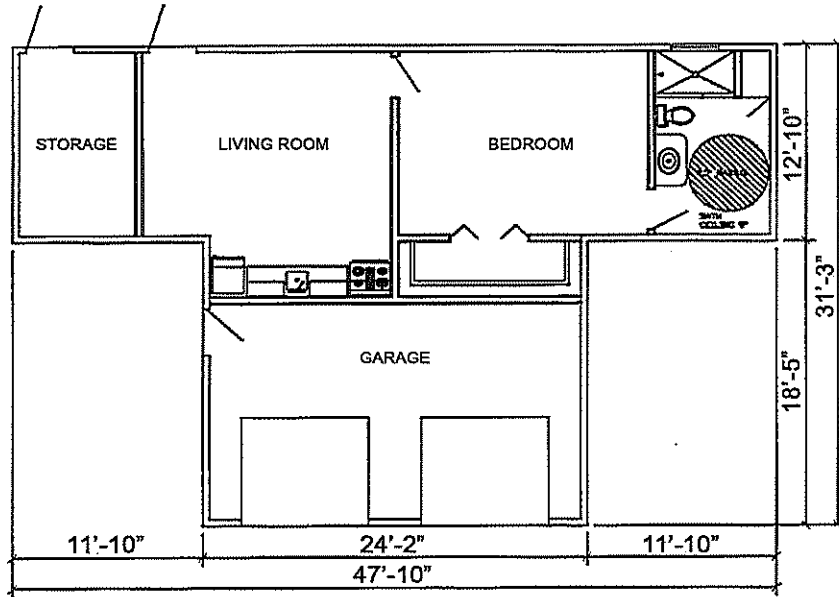

STAFF HOUSE PLAN
SCALE 1/4"=1'-0"

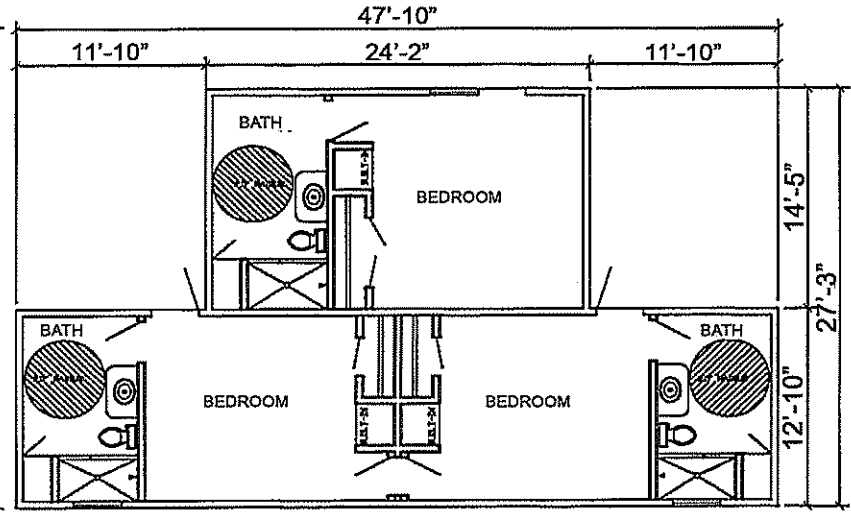

SOLDIER HOUSING PLAN
SCALE 1/4"=1'-0"

Special Use Permit – Board of Adjustment

DRAFT

Ordinance Related Conditions

Group Quarters

Pre- Permit Related:

1. The property owner/developer must submit a scaled detailed drawing for staff review and approval with the building dimensions delineated in addition to showing the exact location and dimensions for the connections of each structure. **Note: The owner is strongly encouraged to discuss the proposed structure layout/connection with a Building Inspector prior to submitting the revision due to the potential for significant increase in building construction costs if the buildings are to be connected. In the event, the owner decides to separate the structures, each structure must be separated by a minimum of 20 feet.**

Permit-Related:

2. The owner/developer(s) of these lots must obtain detailed instructions on provisions of the County Zoning Ordinance and permits required to place any structure within this development from the County Code Enforcement Section, Room 101 in the Historic Courthouse at 130 Gillespie Street. For additional information, the developer should contact a Code Enforcement Officer.

Note: The ordinance has specific building layout requirements for group quarters, including:

- a. Each room must have access to a hall or exterior door;
 - b. There can be no less than one bathroom, consisting of a bath or shower, and lavatory, for each two guest rooms; and
 - c. Guest rooms cannot be equipped with cooking facilities.
3. A fire protection plan approved by the County Fire Marshal must be submitted at the time of permit application.
 4. The County Health Department must approve sewer plans prior to application for any permits. Site and soil evaluations must be conducted on the property by the County Environmental Health Department prior to application for permits. A copy of the Health Department approval must be provided to Code Enforcement at the time of application for any building/zoning permits. (Note: All Health Department requirements must be met prior to issuance of final permits.) (Section 2306 A, Water and Sewer, County Subdivision and Development Ordinance)
 5. Connection to public water is required, the Town of Linden must approve water plans prior to application for any permits. A copy of the Town's approval must be provided to Code Enforcement at the time of application for building/zoning permits. (Note: The developer is strongly encouraged to contact the Town of Linden prior to drafting design plans and commencement of any development on this site, especially regarding the location of sidewalks in relation to the existing and/or proposed Town water lines.) (Section 2306 A.1, Public Water and Sewer Systems, County Subdivision and Development Ordinance)
 6. The developer must provide a site-specific address and tax parcel number at the time of building/zoning permit application.
 7. New development where the developer will disturb or intends to disturb more than one acre of land is subject to the Post-Construction Stormwater Management Permitting Program (Phase II Stormwater Management Requirements) administered by the Division of Water Quality, North Carolina Department of Environmental Quality. If one acre or more of land is to be disturbed, prior to the issuance of any building/zoning permits for this site, a copy of the State's *Post-Construction Permit* must be provided to County Code Enforcement.
 8. For any new development where the developer disturbs or intends to disturb more than one acre of land, the developer must provide the Code Enforcement Section with an approved NC Department of Environmental Quality (NCDEQ) sedimentation and erosion control plan (S&E) prior to any application for permits. (Note: If any retention/detention basins are required for state approval of this plan, then three copies of a revised plan must be submitted and approved by Planning & Inspections prior to application for any building/zoning permits.) A copy of the NCDEQ approval must be provided to Code Enforcement at the time of application for any building/zoning permits.

9. Landscaping provisions do not apply to this development; however, the property owner is encouraged to retain as many existing trees as possible on the subject property.
10. The building final inspection cannot be accomplished until a Code Enforcement Officer inspects the site and certifies that the site is developed in accordance with the approved plans.
11. **Driveway Permit is required.** The developer must obtain a driveway permit from the NC Department of Transportation (NCDOT). A copy of the approved driveway permit must be provided to Code Enforcement at the time of application for building/zoning permits. **Permits MUST be secured prior to the change or alteration of existing or proposed property use. Failure to secure required permits prior to construction or change in property usage may result in the removal of the driveway or street connections at the property owner's expense.** For additional information contact the Division 6 / District 2 office at the number listed on the bottom of this conditional approval.

Note: In the event the NCDOT driveway permit process alters the site plan in any manner, the copies of a revised site plan must be submitted for staff review and approved prior to permit application.

Note: The property owner most likely will be required to provide a copy of a recorded plat and deed conveying to the NCDOT that portion of the subject property located within or to be located within the right-of-way at the time of driveway permit application.

Site-Related:

12. All uses, dimensions, setbacks and other related provisions of the County Subdivision and Development Ordinance and Zoning Ordinances for the A1 zoning district, to include the contents of the application and site plan for the Special Use Permit, must be complied with, as applicable.
13. This conditional approval is not approval of any freestanding signs. If a freestanding sign is desired, re-submittal of the site plan and a \$25.00 revision fee is required prior to application for any freestanding sign permits. Attached signage for this development must be in accordance with the applicable sign regulations as set forth in Article XIII of the County Zoning Ordinance and that the proper permit(s) must be obtained prior to the installation of any permanent signs on the property. (Note: This conditional approval is not approval of the size, shape, or location of any signs.) **Note: If the developer opts for a freestanding sign now or in the future, the sign must be located on the subject property.**

Note: One non-illuminated sign can be permitted, having a maximum dimension of two feet high by three feet wide, and not more than three and one-half feet tall at its highest point above ground level.

14. For any new development, an adequate drainage system must be installed by the developer in accordance with the NC Department of Environmental Quality (NCDEQ) *Manual on Best Management Practices* and all drainage ways must be kept clean and free of debris. (Section 2306 D, County Subdivision and Development Ordinance)
15. For new development, all utilities, except for 25kv or greater electrical lines, must be located underground. (Section 2306 C, County Subdivision and Development Ordinance)
16. In the event a stormwater utility structure is required by the NC Department of Environmental Quality (NCDEQ), the owner/developer must secure the structure with a four foot high fence with a lockable gate, and is required to maintain the detention/retention basin, keeping it clear of debris and taking measures for the prevention of insect and rodent infestation.
17. Turn lanes may be required by the NC Department of Transportation (NCDOT).

Note: The property owner most likely will be required to provide a copy of a recorded plat and deed conveying to the NCDOT that portion of the subject property located within or to be located within the right-of-way at the time of driveway permit application.

18. All lighting is required to be directed internally within this development and comply with the provisions of Section 1102 M, Outdoor Lighting, County Zoning Ordinance.
19. All dumpster, garbage, and utility areas shall be located on concrete pads and screened on a minimum of three sides.

20. All required off-street parking spaces are required to be a minimum of 9' x 20'; a minimum of 19 off-street parking spaces is required for this development.

Advisories:

21. The applicant is advised to consult an expert on wetlands before proceeding with any development.
22. An internal street system most likely will be required to serve any future divisions of the subject property.
23. East Reeves Bridge Road is identified as an existing thoroughfare in the 2040 metropolitan Transportation Plan with no constructions/improvements planned. The subject property will have no impact on the Transportation Improvement Plan. For questions related to this comment, please contact Transportation Planning.
24. The owner/developer is responsible for ensuring easements which may exist on the subject property are accounted for, not encumbered and that no part of this development is violating the rights of the easement holder.
25. The US Postal Service most likely will require this development to have centralized cluster boxes for postal service to each lot or unit. The developer is advised contact the US Postal Growth Coordinator for the Mid-Carolinas District to determine the appropriate location for the cluster boxes. If the cluster box location requires changes to the subdivision or site plan, a revised preliminary/plan must be submitted to the Planning & Inspections Department for review and approval.

Thank you for choosing Cumberland County!

If you need clarification of any conditions, please contact Betty Lynd at 910-678-7602 or Ed Byrne at 910-678-7609 with the Land Use Codes Section; otherwise, contact the appropriate agency at the contact numbers below.

Contact Information (Area Code is 910 unless otherwise stated):

Subdivision/Site Plan/Plat	Ed Byrne	678-7609	ebyrne@co.cumberland.nc.us
Code Enforcement (Permits):	Scott Walters	321-6654	swalters@co.cumberland.nc.us
County Building Inspections:	Gary Faulkner	321-6648	gfaulkner@co.cumberland.nc.us
Fire Marshal – Emergency Services	Rodney Ward	321-6625	rward@co.cumberland.nc.us
County Health Department:	Daniel Ortiz	433-3680	dortiz@co.cumberland.nc.us
Food & Lodging Env. Health:	Daniel Ortiz	433-3680	dortiz@co.cumberland.nc.us
Town of Linden:	Kimberly Turner (Town Clerk)	980-0119	lindentownhall@embarqmail.com
County Public Utilities:	Amy Hall	678-7637	ahall@co.cumberland.nc.us
US Postal Service	Jonathan R. Wallace	(704) 393-4412	jonathan.r.wallace@usps.gov
Corp of Engineers (Wetlands):	Liz Hair	(910) 251-4049	hair@usacr.army.mil
NCDEQ (E&S):	Leland Cottrell	(910) 433-3393	leland.cottrell@ncdenr.gov
US Fish & Wildlife Services	Susan Ladd Miller	(910) 695-3323	susan_miller@fws.gov
Location Services:			
Site-Specific Address:	Ron Gonzales	678-7616	rgonzalez@co.cumberland.nc.us
Street Naming/Signs:	Diane Shelton	678-7665	nameit2@co.cumberland.nc.us
Tax Parcel Numbers:		678-7549	
NCDOT (driveways/curb-cuts):	Troy Baker	486-1496	tlbaker@ncdot.gov
NCDOT (subdivision roads):	Earl C. Locklear	486-1496	elocklear@ncdot.gov
Transportation Planning:	Greg Shermeto	678 7615	gshermeto@co.cumberland.nc.us
N.C. Division of Water Quality:	Mike Randall	(919) 807-6374	mike.randall@ncdenr.gov

cc: Kimberly Turner, Town of Linden

BOARD OF ADJUSTMENT

LOCATION OF PROPERTY: 9390 E. Reeves Bridge Rd Linden, NC 28356

OWNER: John + Deborah Foley

ADDRESS: same ZIP CODE:

TELEPHONE: HOME 910-729-0526 WORK 910-323-0965

AGENT:

ADDRESS:

TELEPHONE: HOME WORK

E-MAIL: Johnmfoley3@gmail.com

APPLICATION FOR A SPECIAL USE PERMIT
As required by the Zoning Ordinance

A. Parcel Identification Number (PIN #) of subject property: 0554-51-6231
(also known as Tax ID Number or Property Tax ID)

B. Acreage: 18.72 Frontage: 131' Depth: 1605'

C. Water Provider: Linden

D. Septage Provider: N/A Septic tank

E. Deed Book 00127 8512, Page(s) 0733, Cumberland County Registry. (Attach copy of deed of subject property as it appears in Registry).

F. Existing use of property: Equestrian Facility

G. It is proposed that the property will be put to the following use: (Describe proposed use/activity in detail including hours of operation, number of employees, signage, parking, landscaping, etc.)

Lone Survivor Foundation Retreat Facility

See attached Trifold

40 retreats per year;

The undersigned hereby acknowledge that the County Planning Staff has conferred with the petitioner or assigns, and the application as submitted is accurate and correct.

✓ John M Foley & wife Deborah
NAME OF OWNER(S) (PRINT OR TYPE)

✓ 9390 East Reeves Bridge Rd. Linden, NC 28356
ADDRESS OF OWNER(S)

John M Foley Johnmfoley3@gmail.com
E-MAIL

910-729-0526
HOME TELEPHONE #

910 323-0965
WORK TELEPHONE #

John M Foley
NAME OF AGENT, ATTORNEY, APPLICANT (PRINT OR TYPE)

same
ADDRESS OF AGENT, ATTORNEY, APPLICANT

same
E-MAIL

same
HOME TELEPHONE #

same
WORK TELEPHONE #

[Signature]
SIGNATURE OF OWNER(S)

[Signature]
SIGNATURE OF AGENT, ATTORNEY OR APPLICANT

Deb Fy
SIGNATURE OF OWNER(S)

The contents of this application, upon submission, become "public record."

STATEMENT OF ACKNOWLEDGMENT

Regarding appearance before the Board of Adjustment, the undersigned owner(s), agents, or their assigns, by virtue of their signature(s) to this application, hereby acknowledge the following:

- That although appearance before the board is not required, it is strongly encouraged;
- The board will hear any and all argument for and against this matter before them and such relevant facts will be given under sworn testimony;
- At the public hearing the board has the authority to approve, deny, or defer the request for additional information to be provided;
- If the petitioner or their representative for this application does not appear personally before the board, whether there is opposition or not, the board has full authority to consider the case.
- If the board's decision is to deny the matter before them, the aggrieved party shall file a **"Notice to Intent to Appeal" with the Planning & Inspections Staff on the next business day following the meeting in which the board's decision was made final, or the next business day following receipt of the written copy thereof.**
- Any petition for review by Superior Court shall be file with the Clerk of Superior Court within 30 days after the decision of the board is made final.

Signed acknowledgment that the Planning and Inspections Staff has explained the application process and procedures regarding this request and the public hearing procedure stated above.

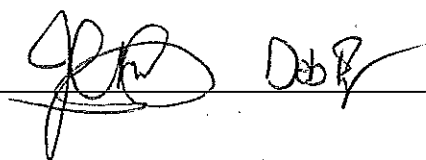
SIGNATURE OF OWNER(S) 

PRINTED NAME OF OWNER(S) John M Foley + wife Deborah

DATE 6/19/17